

# Digital Twin Enables Predictive Maintenance for Solar Power Plant

Multi-national utility company, ENGIE, collaborates successfully with Modelon to build digital twin for predictive maintenance on solar power plant.



## INTRODUCTION

ENGIE, a leading global utility company, made a strategic shift several years ago – committing to accelerate the growth of renewable energy and the transition towards a carbon-neutral economy. They began building a robust foundation for long-term growth; successfully reducing energy consumption and investing in renewable sources that benefit everyone throughout the value chain – from businesses, to suppliers, to clients.

## ENGIE'S SOLAR POWER EXPANSION AND NEED FOR PREDICTIVE MAINTENANCE

With currently hundreds of solar installations around the world, ENGIE aims to double the capacity and production of solar power supply by investing in innovative solutions that can harness solar power - including concentrated solar power plants and organic photovoltaic, centralized, and decentralized production solutions, sometimes combined with energy storage.

To ensure ENGIE's reliable, efficient, and sustainable electricity mix, ENGIE's growing solar capacity needs to operate reliably and efficiently. Maximizing the delivery of solar power without any disruption ensures ENGIE's economic value. While generation monitoring gives an indication of the health of the plant or a subsystem in the plant, the sensor data is generally insufficient to provide a root cause of an anomaly. Plant inspection is costly and time-consuming: solar plants are often located in desolate locations.

>>>>



### PROBLEM

Pinpoint area of performance degradation in a solar power plant



### SOLUTIONS

Modelon Impact  
Project Consulting Services



### RESULTS

Powered with an accurate digital twin ENGIE determined the precise location of a broken fuse.



Modelon Impact





“Modelon’s team of industry experts gave us the confidence to move forward. Their knowledge of renewable systems and infrastructure as well as their physics-based modeling was exactly what we needed. In a short amount of time, we were able to have a model in hand, integrate it into our own platform, and resolve an error that was preventing our solar power plant from running efficiently – saving time and money.”

**Benedicte Piret**, Project leader, and  
**Cristian Solís**, IT integration specialist

## ENGIE ENERGÍA CHILE PILOT PROJECT OF DIGITAL TWIN

In Chile, ENGIE’s asset management team could recognize a performance degradation through instabilities in generation production in the plant of El Aguila, a plant with 7,600 solar panels and numerous inverter components. Pinpointing the fault and area needed for maintenance was critical, especially from afar. With Modelon expertise in energy asset operation and advanced modeling and simulation software - Modelon Impact - a complete digital twin was built and validated in the context of this pilot project.

The accuracy of the Modelon Impact digital twin enabled the ENGIE team to successfully determine the precise location of several broken fuses at the very moment of their failure, and schedule maintenance accordingly.

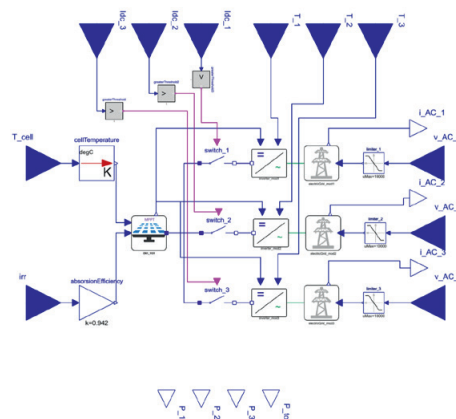

Pairing real-world data with a virtual representation of the system provided ENGIE with a bird’s-eye view of the entire power system’s health, down to the component level, remotely. The predictive nature of the physical system model in the digital twin permitted the extrapolation of measurement data to actionable failure detections. Subsequently, the digital twin would also

provide ENGIE with the ability to anticipate component failures and maintenance – optimizing costly maintenance activities of their assets.