

AIR CONDITIONING

LIBRARY

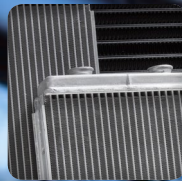

- Rapid design and simulation of air conditioning systems for virtual prototyping, component dimensioning, and control system design

The Air Conditioning Library is a library for design, analysis and optimization of automotive air conditioning systems. Air Conditioning Library contains both ready-to-use refrigeration cycle templates and a wide range of components to create non-standard configurations. System architecture and dynamic behavior can be studied at an early design stage. Pre-defined steady-state experiments facilitate calibration and validation with experimental data on a component level and can be easily combined with FMI-based post-processing solutions such as FMIE (Add-on

for Excel). The dynamic system model with validated components may then be further used in charge optimization, control design, and performance studies.

Air Conditioning Library is useful for manufacturers and suppliers in the automotive and aerospace industry who design A/C systems and could benefit from virtual testing of their components in different system configurations. In academia, Air Conditioning Library gives students insight into phenomena and component interactions which are difficult or impossible to observe on a test-rig.

KEY FEATURES

- State-of-the-art A/C models with access to source code
- Single model handles both transient and steady-state simulation
- Easy-to-use templates can be adapted for custom needs
- Wide range of refrigerants, including R134a, R744, R404a, R1234yf
- Based on the Modelica Language open standard

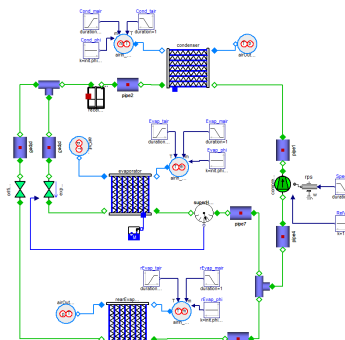
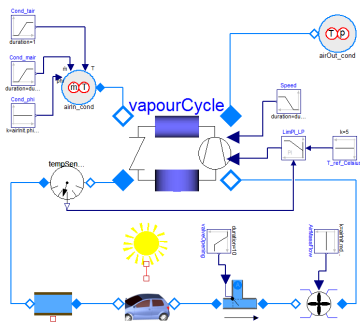

Modelon