

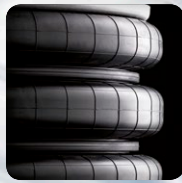

PNEUMATICS LIBRARY



- Modeling and simulation of pneumatic systems for system design, component sizing and control design.

Pneumatics Library allows you to verify and optimize the design of your complete pneumatic system from early design phases to production. Applications include automotive suspensions and brake systems, machine

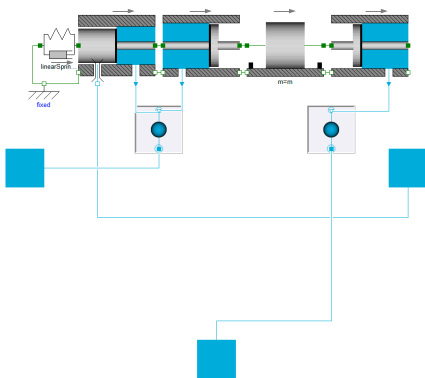

tools, and jackhammers. This includes in particular construction equipment and suppliers, commercial vehicle design and manufacturing companies and the aerospace industry.

Pneumatics Library provides components for the modeling of cylinders

and motors, valves and nozzles, lumped volumes, lines and sensors. A standard pneumatic system circuit can be readily built using the existing components in the library. If, however, specially designed components are used these can be easily modeled by modifying library components. User gets the best modeling experience due to the acausal nature of the component models. Pneumatics Library has capability to create any type of valve from the scratch using Elements sub-package.

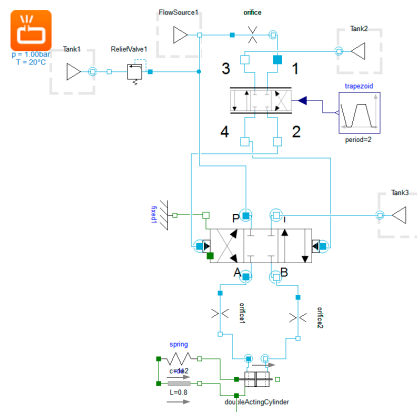

These valve models will be of higher fidelity that is useful for valve designers.

The library models are based on extensive literature research, several years of experience and validation in research applications and industrial projects. The models can also be used for real-time and hardware-in-the-loop applications.

KEY FEATURES

- System and component design in the same tool
- Easily integrated into any application domain
- Well suited for control design
- Fast, real-time capable
- Wide range of standard components
- Open, customizable & well documented

